

Integration of APC I/O signals into the Edge Connect CNC controller from Hypertherm

Task: The IHT APC Stations are handling all process related tasks itself. The CNC is responsible for starting the process and start moving when the APC system is ready to pierce. The Operator Panel for APC is a separate device next to the Edge Connect panel

Solution: APC will handle the full cutting process and Edge Connect only sending start/stop signal and taking care of motion.
 We suggest to set it up as a plasma with lifter “other” and then either plasma-1 or plasma-2 as “other” depending on your general configuration.
 Then use cut-sense 2 and cut-control 2 as if it was a generic plasma. All torch height I/Os are handled inside the APC System.
 By doing this all the Oxy-Fuel will run from the APC controller and Phoenix are not using any of the oxy features.

Required products

- One or more APC Stations
- APC Operator Panel

- Edge Connect

Function:

APC Station

Edge Connect

I/O

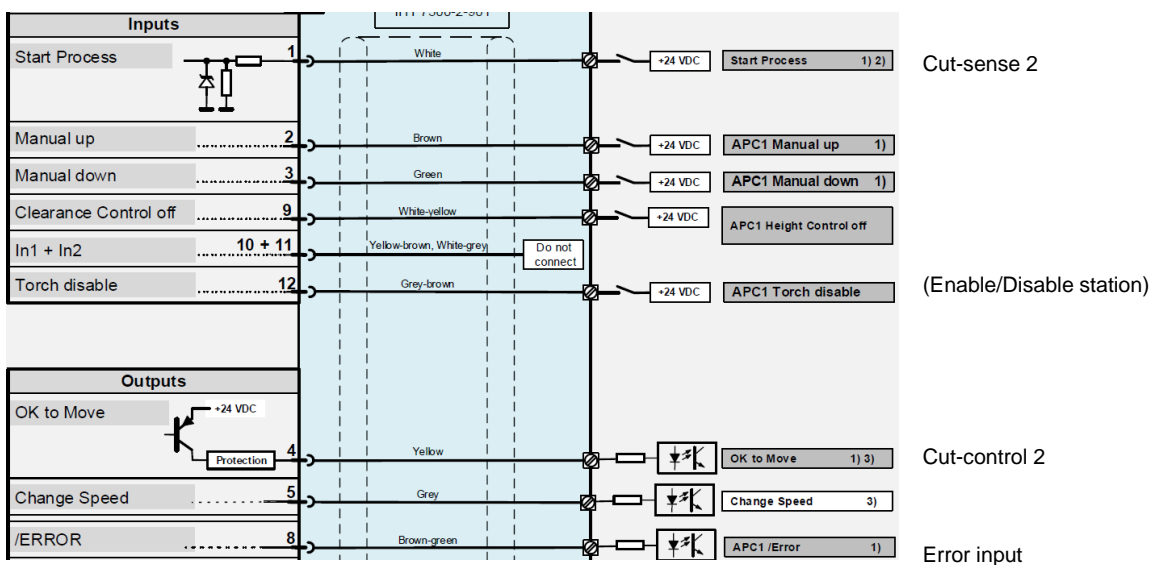

Reference: Please find further information about APC here: <https://www.iht-automation.com/login/>